

## Heat On Demand Advantage® CV+ Induction Heating Activator Model ADV600E

Our compact Heat On Demand Advantage® CV+ induction base heating activator offers impressive food temperature-holding performance, fast base heating, and exclusive intelligent features that increase user efficiency. CV+ consistently activates Advantage bases in just 12 seconds and maintains food temperature at or above 60°C for 60 minutes when using a preheated china plate and our Radiance® high-performance insulated dome¹.



The prominent **LED status light** displays a different vibrant color at every stage.

**HEAT ON DEMAND**

Advantage **CV+**



**60**

**MINUTES**  
HOLD TIME



**12**

**SECONDS**  
CYCLE TIME

### Heat On Demand Advantage® CV+ Benefits

- Hot food for higher patient satisfaction scores.
- Time-tested design and component reliability.
- Simple operation for greater employee satisfaction.
- Impressive temperature holding performance.

### Performance

- Maintains food temperatures at or above 60°C for 60 minutes using a preheated plate and our Radiance insulated dome¹.
- Consistent 12-second base heating cycle activates up to 5 bases per minute.
- Uses cool-to-the-touch Advantage bases that fit most standard 23 cm plates.

### Construction

- Durable stainless steel countertop design.
- Solid-state electronic controls for enhanced reliability.
- Robust polymer centering guide for hassle-free base insertion and removal.
- Designed for use in commercial kitchens.

### Standard Features

- **LED status light** provides clear visual and audible cycle alerts: white / idle, red / base heating, green / base ready, yellow / error.
- **Automatic voltage calibration** adjusts for 380 to 415-volt power, so **voltage fluctuations will not affect base heating cycle time.**
- **Automatic base holding cycle** keeps bases ready for use during pauses in tray assembly.
- **Error prevention logic** eliminates the guesswork for easy operation.
- **Automatic power shut-off** conserves electricity when not in use.
- Internal fans keep electronics cool during heavy use.
- Base and activator diagnostics.
- Easy to remove washable air filter.



### Sustainability

Efficient induction technology provides significant energy savings.

- Energy-efficient induction technology.
- Automatic shut-off conserves electricity when not in use.

# Heat On Demand Advantage® CV+

## Induction Heating Activator

### Model ADV600E

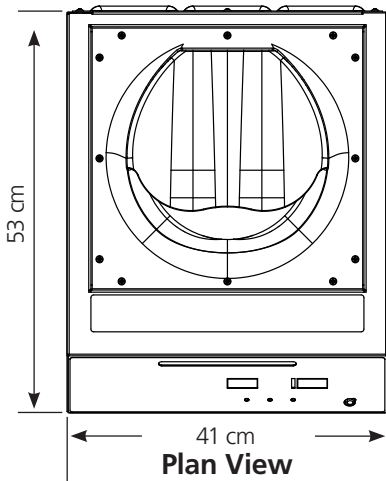

### Advantage CV+ System

Activates Advantage (IHB26) bases which accommodate standard 23 cm dishware.

Visit [aladdintemprite.com](http://aladdintemprite.com) to see all Advantage base color options.

Heat On Demand Advantage® bases stay cool on the sides, so they're safe to handle without gloves or a base lifter, and they're safer for patients and residents, too.

Use only with Aladdin Heat On Demand Advantage® bases.

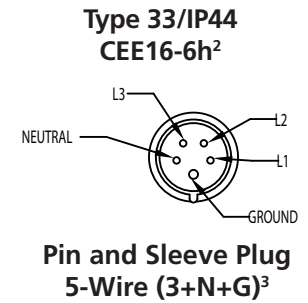
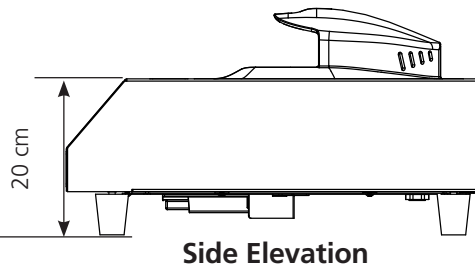
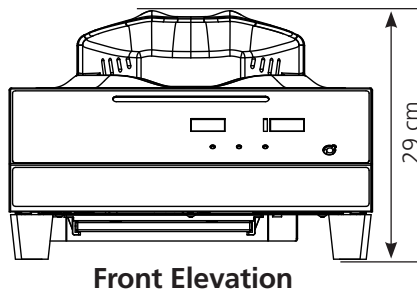

### Heat on Demand Advantage® CV+ Technical Specifications

Model Number	Electrical <sup>2</sup>	Cord Set/ Plug	Width	Depth	Height	Weight	Shipping Weight
 ADV600E	Volts: 400 Hertz: 50/60 Phase: Three Max amp draw: (9.5) Min. amp capacity: 16	16A-6h Type 33/IP44 5-Wire (3+N+G) 167.6 cm cord with pin and sleeve plug	41 cm	53 cm	29 cm	15 kg	22 kg

<sup>1</sup> 311 grams of food input at 74°C with a 74°C preheated plate and Radiance® high-performance insulated dome. **Changes in food load, input temperatures, or Aladdin dome may affect holding time.**

<sup>2</sup> Unit should be operated on a 16-amp dedicated circuit. Wall or raceway receptacle number Type 1385 (16A-6h), drop cord connector number Type 15A (16A-6h). **NORMAL OPERATION +10/-5% POWER SYSTEMS.**

<sup>3</sup> B-type RCD required (Non-linear Inductive Load).

<sup>4</sup> Facility to maintain stable power quality to include minimum circuit power factor of 80% under load.

<sup>5</sup> **TO PROTECT PRODUCT RELIABILITY:** Maintain electrical harmonic voltage THD (v) of 8% or less and harmonic current THD (I) of 15% or less under load.

Complies with CISPR 14/EN55014/EN6100.



Visit [aladdintemprite.com/patents](http://aladdintemprite.com/patents) for patent information.

250 E. Main St. | Hendersonville, TN 37075 | Customer Service: 800.888.8018 | Tech Service: 800.888.5426 | Fax: 888.812.9956 | [aladdintemprite.com](http://aladdintemprite.com)

©2023 Aladdin Temp-Rite.® All rights reserved. Note: Specifications are subject to change without notice.



S230310ADVCV+ Rev-1